

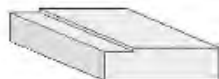

STRAIGHT LINE EDGE
MACHINE TOOLING

Straight line edge machine tooling for GRANITE and ENGINEERED STONE



Calibrating wheel

Diameter	Fitting	Grit	Sysnr	Price
EUR				
190mm	50mm	M8	34205048	210
250mm	50mm	M8	34205049	255
260mm	50mm	M8	34205047	255



Chamfer/Bevelling wheels

Diameter	Fitting	Grit	Sysnr	Price
EUR				
155mm	50mm	M78	300592	530
150mm	50mm	80BN	34349956	305

Generating wheels



943077



300555 - 34348676 - 34007976



300553 - 300554
377215 - 300570



356408 - 34332750



Diameter	Fitting	Grit	Sysnr	Price
EUR				
120mm x 30mm - reinforced wheel	40mm	M9	943077	275
120mm x 34mm	M18	M9	300555	265
130mm x 47,5mm	M30	M9	300554	340
130mm x 47,5mm	Snail fitting	M8	356408	340



Grooving disc

Different machine attachments and diameters available on request

Guidelines for Tools for Ceramic slabs on straight bevelling and profiling machines

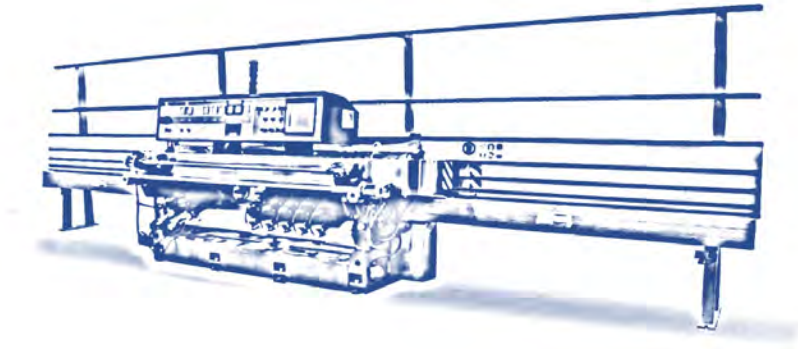

On the market there are various brands and models of machines already used for working on artificial stones and glass. The main processes are making and polishing of straight or shaped edges. Depending on the machine model, suitable geometry tools and specifications are available. Vincent can help you define the correct sequence of tools for every machine.

Metal and resin bond cup wheels

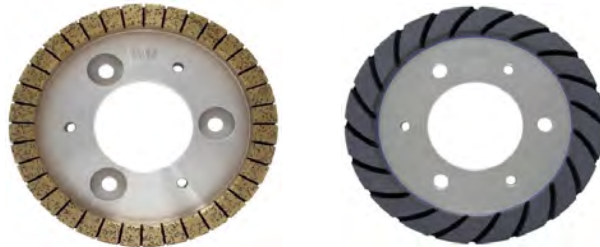

Profiling wheels



Main processes:



Choice of tools for straight grinding machines for Ceramic slabs:



For a correct selection of tools please provide us with the following information about the machine and the material to be processed:

REQUIRED INFO	
machine manufacturer	
machine model	
application	
material	
material thickness	

A wide range of tools is available to meet customers' needs. Please find below some of the most used types:

metal bond cup wheels

\varnothing (External)	Band
150 / 175 mm	
	36 segm. 30° 32 segm. Z32 segm. 20 segm. semi-segments 10 slots continuous band

resin bond cup wheels

\varnothing (External)	Band
150 / 175 mm	
	16 slots semi-segments continuous band

Profiling wheels

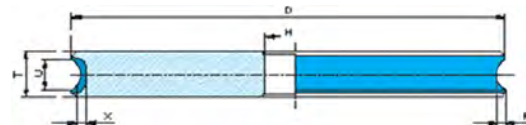

\varnothing (External)	T X U P H
--------------------------	-----------



